

Chocolate Treasure Chest

What you will need:

- 1 half sheet pan
- Cellophane or parchment paper
- Approximately 1 cup dark wafer chocolate
- Approximately 2 cups white wafer chocolate
- Yellow candy color and other colors for jewels are optional
- Metallic Dragees
- Min marshmallows
- Optional: graham cracker crumbs
- Treasure Chest Template
- Pastry cones
- Small glass or microwave safe bowls
- Rubber spatulas
- Heating pad to keep to chocolate pastry cones at their ideal temperature



How to:

1. Place the template on a sheet pan or flat surface. Cover it with cellophane or parchment paper. If necessary, lightly secure the cellophane with one or two pieces of tape.
2. Melt the white and dark wafer chocolates.
3. Divide approximately 4 tablespoons of the dark chocolate between two pastry cones. Prepare the tinted chocolate: approximately 2 tablespoons yellow and 1 cup medium brown (mix white and a small amount of chocolate together). If desired make assorted colors for jewels. Pour the chocolates into separate pastry cones.
4. Cut a very small hole in the dark chocolate pastry cone and pipe delicate wood grain over all of the template shapes. Fill in the shapes with medium brown. Let cool, but before the chocolate has set completely trim the edges with a paring knife so that they are all straight. Also cut ¼-inch strips from the largest shape (labeled as “slats”). When the chocolate is hardened, carefully flip the designs and gently peel off the cellophane.

step 5

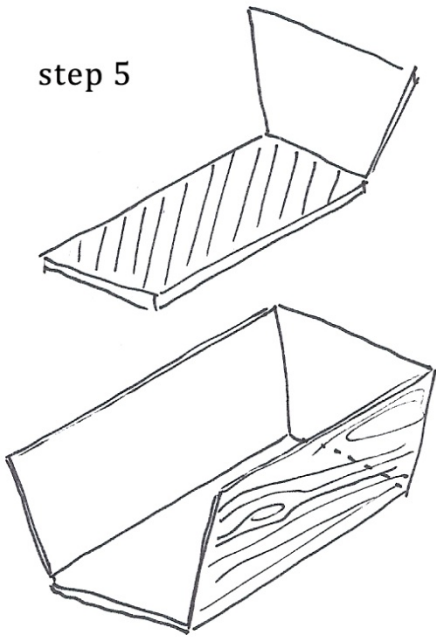

5. Place the base on a sheet pan lined with parchment paper or cellophane. Using chocolate as “glue”, pipe a line on one short edge of the base and adhere a B SIDE to it (the narrow end facing down). Pipe a chocolate line up each vertical end of the B SIDE and on both long edges of the base. Adhere one A SIDE to each long side of the base so that they also adhere to the B SIDE. You may have to hold them in place for a moment for the chocolate to set. The A SIDES should be flared out slightly. Pipe chocolate up the exposed vertical edges of the A SIDES and along the remaining short edge of the base and attach the last B SIDE.

step 6

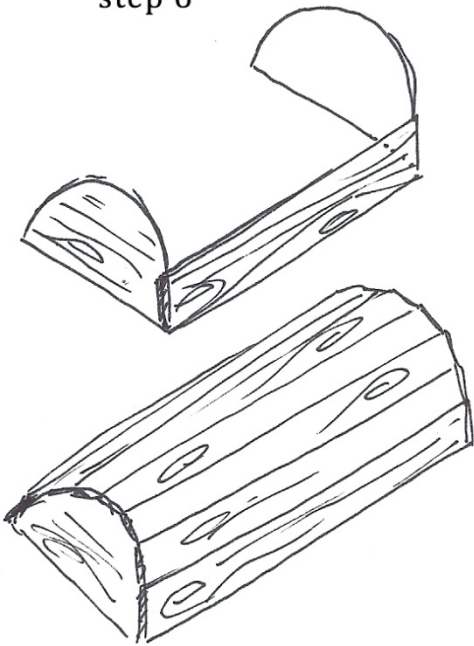

6. Place the flat edge of a TOP SIDE on the lined sheet pan. Pipe a dot of chocolate on the bottom outer edge of one side. Adhere one slat to this dot (perpendicular to the TOP SIDE, flush with the top edge, and resting on the sheet pan), holding in place until set. Pipe a dot on the opposite end of the slat and attach the other TOP SIDE (again keep perpendicular). Pipe dots of chocolate on the outer edge of both TOP SIDES directly next to the first slat. Attach the next slat to these dots, so that it rests against the first slat. Continue this pattern around the entire curved edge of the TOP SIDES. If the last slat doesn't fit perfectly, carve or score and break, it to fit.

7. Pipe chocolate lines up all of corners of the base and around the curvature of the TOP SIDES. It is OK if some chocolate pools at the bottom – you can trim it off later. Overpipe yellow dots on the chocolate lines (use photo as guide).
8. Fill the base with mini marshmallows. Pipe chocolate over the marshmallows, completely covering them. Before the chocolate sets sprinkle dragees on top. If desired pipe on multicolored jewels.
9. Arrange the treasure chest atop graham cracker crumbs or a cake.